

R-405



L.P. Pilot Valve

Features:

- Pilot actuates valve with low pressure signal
- Micro gap construction - snap action and no blow by
- Balanced design allows speed control at exhausts

Performance:

Flow: 9 scfm @ 100 psig; 255 l/min @ 6.9 bars

Pilot Pressure Minimum: 15 psig; 1.0 bar

Temperature: 32 to 180°F

Working Pressure: 0 to 150 psig; 0 to 10.3 bars

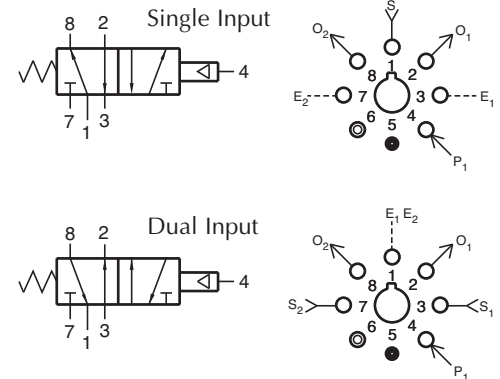

Description:

R-405 is a 4-way, spring-return, fully ported 5-port valve with a low pressure pilot. Pilot pressures as low as 15 psig will actuate the valve. It can perform all 2, 3, and 4-way functions. Operates double acting cylinders, allows speed control by restricting exhaust ports. It can be used with 1 input, 2 independent outputs and two independent exhausts, or with 2 independent inputs, 2 independent outputs and a common exhaust. The R-405 may be used in place of an R-401 where lower pilot actuation pressure is desired.

R-410



4-Way Reset Valve

Features:

- Indicator shows valve in shaded position
- Micro gap construction - snap action and no blow by
- Balanced design allows speed control at exhausts
- Unique piloted spring reset

Performance:

Flow: 9 scfm @ 100 psig; 255 l/min @ 6.9 bars

Pilot Pressure Minimum (against spring): 40 psig; 2.8 bars

Pilot Pressure Minimum (spring retracted): 20 psig; 1.4 bars

Temperature: 32 to 180°F

Working Pressure: 0 to 150 psig; 0 to 10.3 bars

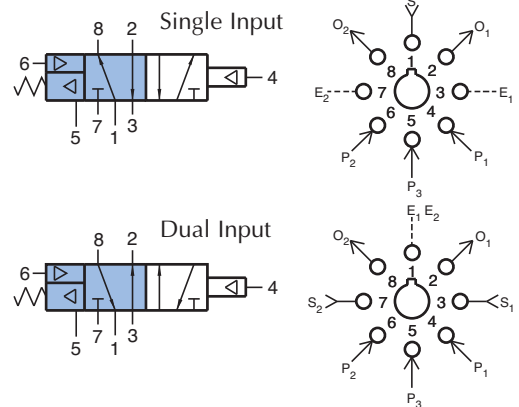

Description:

R-410 is a 4-way, fully ported valve with a special air retracted spring return that will return the valve to a definite position when there is no signal at ports 5 and 4. This "reset" feature may be used in circuits in the event of loss of air pressure or to change the operating characteristics of the valve in the circuit in response to an independent input at port 5. When port 5 is not piloted, the R-410 acts as a R-401 4-way spring return, fully ported valve. When port 5 is actuated, the R-410 acts as an R-402 4-way, two position valve. With no signal at port 5, a signal at port 6 acts as an auxiliary pilot type valve and will override a signal at port 4.